

ROLL OUT RACKS

MANUFACTURED BY  INDUSTRIUM

STRONG DEPENDABLE SOLUTION

ROLL OUT PALLET

Innovate with the roll out pallet

Amongst the different elements of handling and storage equipment that we've developed, we have the **Roll Out Pallet**. This product responds to your reality by increasing execution speed all the while optimizing space and safety. Your inventory is a crucial element in the production process, and its importance is paramount. As a result, the Roll Out Pallet will easily give access to your material and greatly facilitate the gathering process and management of your inventory. Hence, the Roll Out Pallet units are durable and well suited to your handling and storage needs.

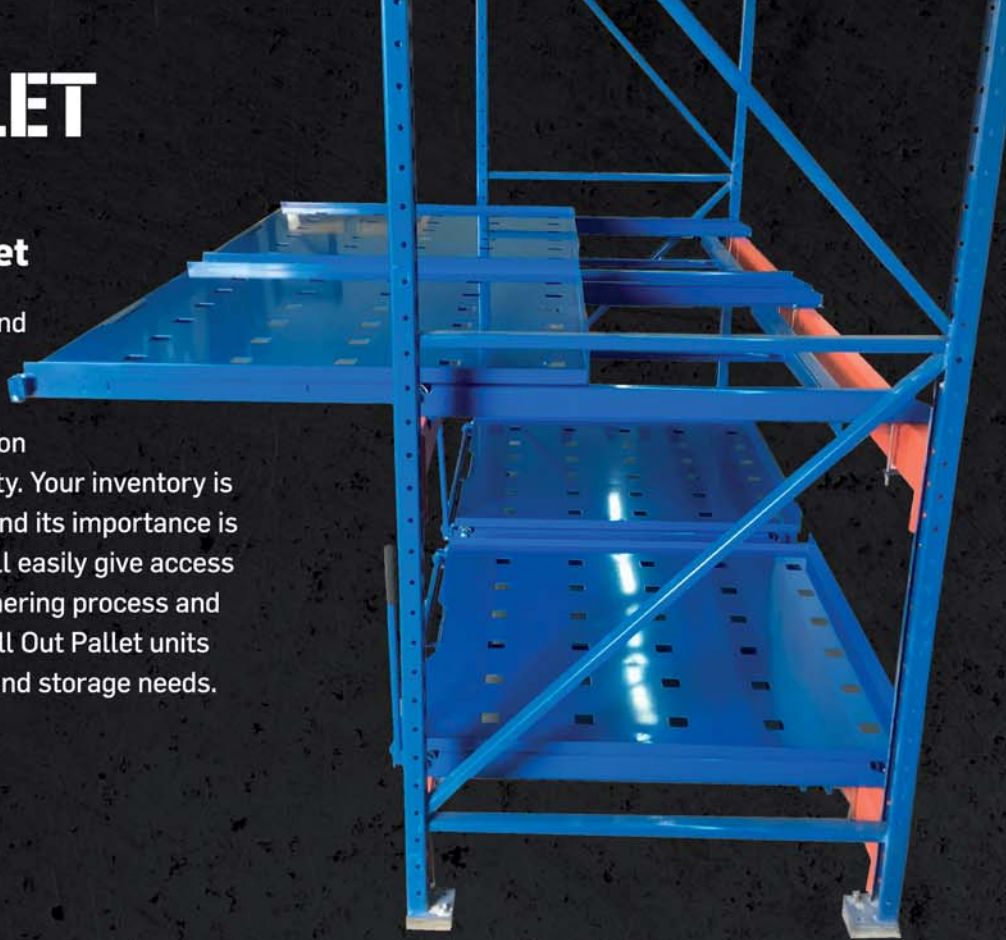

OUR STORAGE STRUCTURES

- ✓ Maximum capacity: 1000-lbs per unit
- ✓ Extension: 75%
- ✓ 48" wide x 42" deep
- ✓ 42" wide x 42" deep
- ✓ 42" wide x 48" deep
- ✓ 48" wide x 48" deep
- ✓ Custom sizes available
- ✓ For beam installation, it can accommodate sizes up to 2" x 6" beams

**ROLL OUT
RACKS**
MANUFACTURED BY **INDUSTRIUM**

TOP VIEW

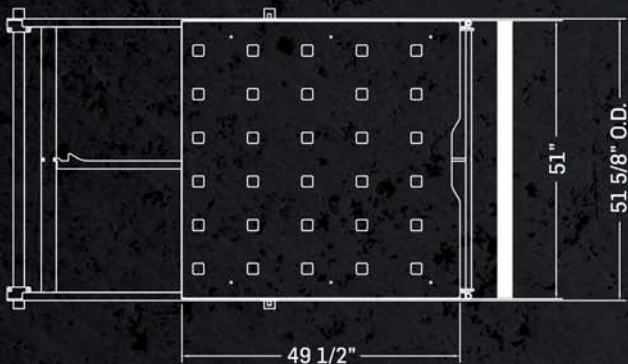

FRONT VIEW

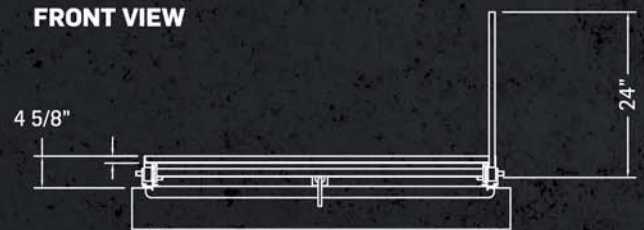

SIDE VIEW - OPENED

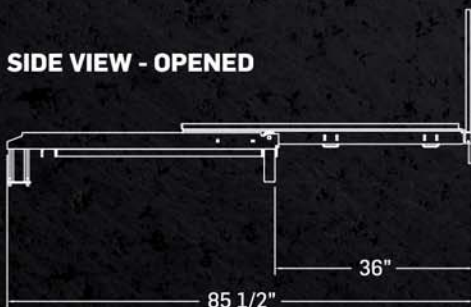

SIDE VIEW - CLOSED

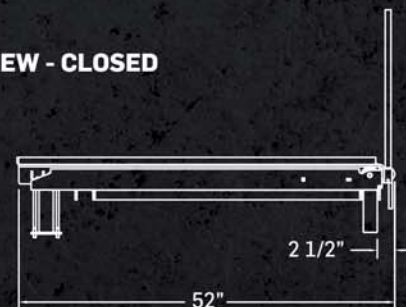

ROLL OUT RACKS

MANUFACTURED BY **INDUSTRIUM**

REQUEST QUOTATION FOR MODULAR RACKING

Date: _____ Customer name: _____
Distributor: _____ Customer city: _____
Contact: _____ Email: _____
Phone number: _____ Other information: _____

GENERAL INFORMATION

QUANTITY: _____

Installation: Rack Mounted

Dimension: 48"W x 48"D 48"W x 42"D 42"W x 42"D 42"W x 48"D

Top plate: Yes Perforated No

Backstop: 1" 2" 3" Special No

Endstop: 1" 2" 3" Special No

Extension: 75%

Lock system: Yes No

Removable Pull Handle: 24" High 36" High Other

Capacity: 1,000 lbs UDL Other

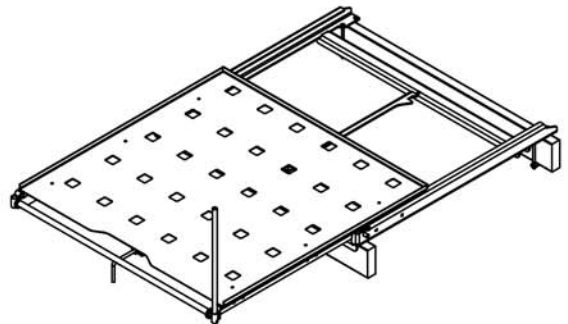
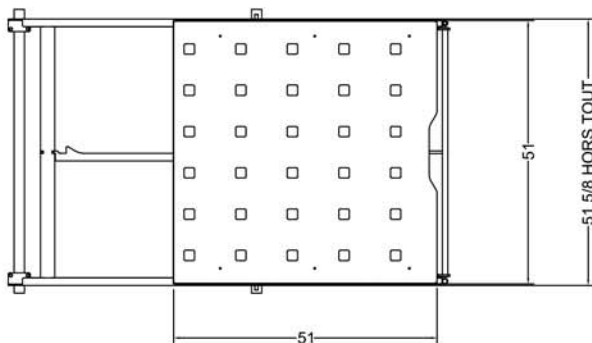

FLOOR MOUNTED ROLL OUT PALLET

Keep it even more accessible: Floor mounted Roll Out Pallet

Hand picking is now made easier with the **Roll Out Pallet** installed directly on the floor and sliding the material out of the rack. Safe and efficient they roll on tracks installed on the floor so no one can take them out of the place. Made out of thick steel and heavy duty rollers, they withstand the harshest environments. The standard brake system securely holds the Roll Out Pallet in place when the lift is loading it. No more dangerous handling. Additionally, since you no longer need to crawl under to access your material, you can gain the extra space by lowering first level of beams.

OUR STORAGE STRUCTURES

- ✓ Maximum capacity: 2,500 lbs per unit
- ✓ Extension: 95%
- ✓ 48" wide x 42" deep
- ✓ 42" wide x 42" deep
- ✓ 42" wide x 48" deep
- ✓ 48" wide x 48" deep
- ✓ Custom sizes available
- ✓ Requires lagging tracks on the floor



TOP VIEW

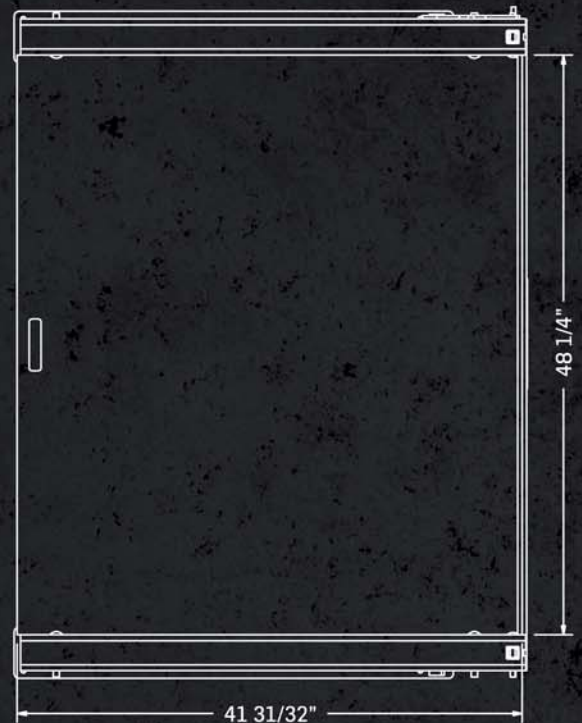

FRONT VIEW

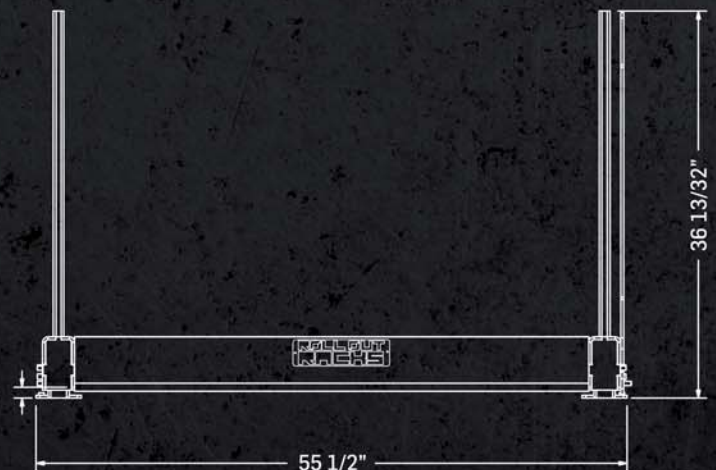

ROLL OUT RACKS

MANUFACTURED BY  **INDUSTRIUM**

REQUEST QUOTATION FOR FLOOR MOUNTED MODULAR RACKING

Date: _____ Customer name: _____
Distributor: _____ Customer city: _____
Contact: _____ Email: _____
Phone number: _____ Other information: _____

GENERAL INFORMATION

QUANTITY: _____

Installation: Floor Mounted Floor Mounted Low Profile

Dimension: 48"W x 48"D 48"W x 42"D 42"W x 42"D 42"W x 48"D

Top plate: Yes Perforated No

Backstop: 1" 2" 3" Special No

Endstop: 1" 2" 3" Special No

Extension: 100% Other

Lock system: Yes No

Removable Pull Handle: 24" High 36" High Other

Capacity: 2,500 lbs Other

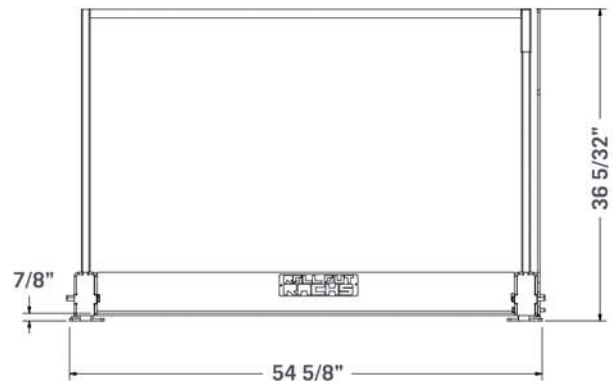
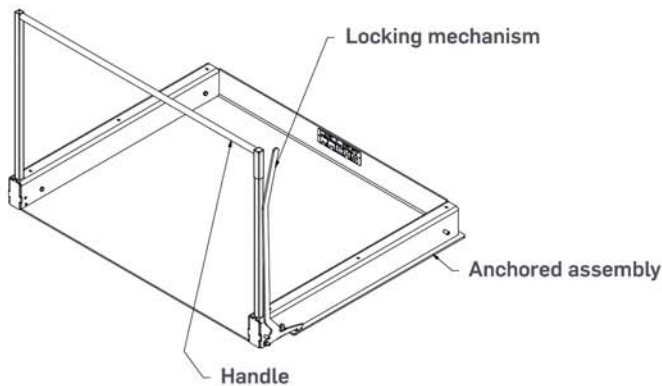



CANTILEVER RACK

Free space, gain storage

The Roll Out Cantilever Racks allows you to store long materials inside a drawer system. With these racks, you will not only be able to free up to 50% of your floor space, but your employees will no longer have to find material by digging through dangerous piles. In the end, this greatly increases safety and time optimization. The drawers completely open, allowing you full access to your materials and facilitating handling with a hoist.

Commonly known as bar rack or pipe racks, the Roll Out Cantilever Rack's drawer system is adjustable every 3", allowing you to change your setup according to your needs. You ensure yourself better control of your inventory by utilizing the drawer dividers or the full drawers for short or flexible material. After introducing the Roll Out Cantilever Rack to your workspace, your operations will become more profitable and safer.

TOP VIEW

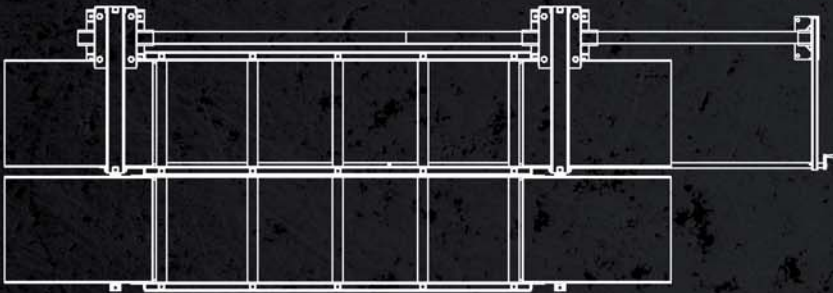

FRONT VIEW

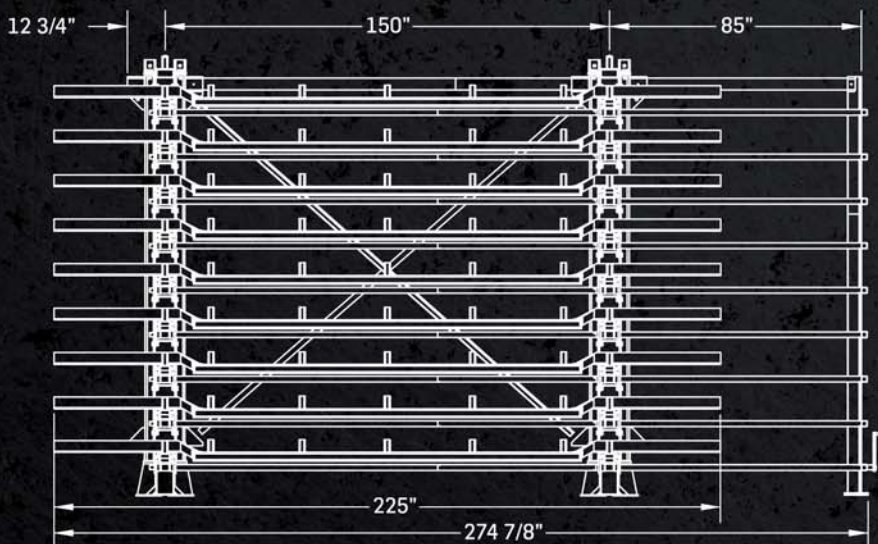

SPECIFICATIONS

- ✓ Standard lengths: 12', 20', 24', 36' or 40'
- ✓ Height: 100", 124", 148" or 184"
- ✓ Drawer depths: 20", 24", 30" or 36"
- ✓ Drawer capacity starting at 3,900 lbs
- ✓ For 12', 20', 24', 36' or 40' materials
- ✓ Minimum space between the drawers adjustable every 3 inches
- ✓ Drawers open 100%
- ✓ Top capacity: 15,000 to 30,000 lbs

ROLL OUT RACKS

MANUFACTURED BY  **INDUSTRIUM**

REQUEST QUOTATION FOR CANTILEVER RACK

Date: _____ Customer name: _____
Distributor: _____ Customer city: _____
Contact: _____ Email: _____
Phone number: _____ Other information: _____

GENERAL INFORMATION

Modular racking type: Double Single
Support column height: 100" 124" 148" 184" (double only) Other _____
Quotation number (Reserved for Roll Out Racks) _____

DRAWER INFORMATION

Arm depth: 20" 24" 30" 36" **Material length:** _____
Arm level capacity: _____ **Number of levels:** _____
Minimum spacing required between each level: _____

OPTIONS

Choice of shelf: Without extended shelf
 Open extended shelf (Quantity _____)
 Full extended shelf (Quantity _____)
Adjustable separator's support bracket:
 Open extended shelf (Quantity _____)
 Directly on arm (Quantity _____)
Adjustable separator:
 4" 7" 10" 13" 16"
 19" 22" Total quantity: _____
Welded separator (not illustrated)
 4" 7" 10" 13" 16"
 19" 22" Total quantity: _____

REPRESENTATION

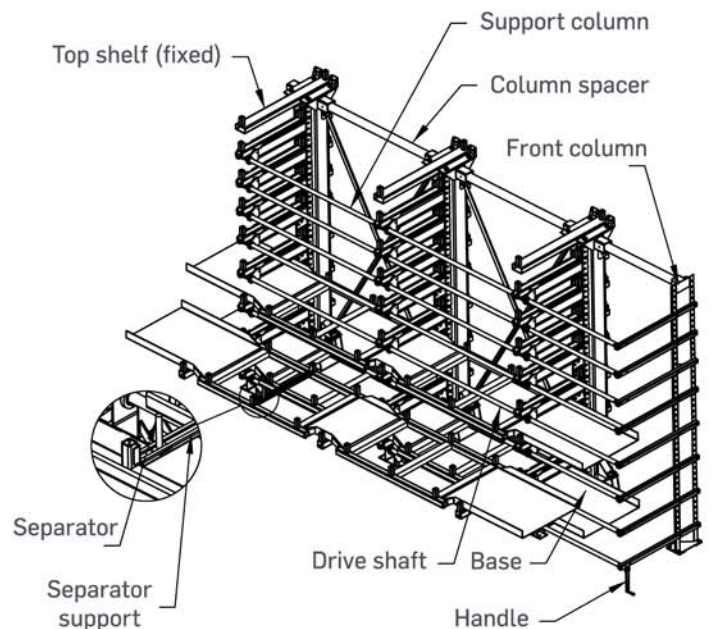

SHEET RACK

One of our solutions: Roll Out Sheet Rack

We have created several high-quality products, the Roll Out Sheet Rack being one, that allow you to both store a number of important items and that can hold up to 5,000 lbs. They can also be personalized to remove or add extra shelves. In using the Roll Out Sheet Rack as a storage system, you free a considerable amount of floor space, which helps your employees better move around in their workspaces. You increase productivity as well as safety in your workplace. In order to best adapt to your needs, we can offer several different shelving models.



SPECIFICATIONS

- ✓ Shelving with retractable drawers
- ✓ Add or remove individual shelves
- ✓ 6 models available from 4'X4' to 6'X12'
- ✓ Drawer capacity: 5,000 lbs
- ✓ Up to 8 drawers per shelf
- ✓ Maximum levels: 8

OPTIONS

- ✓ Larger, with a 11,000 lbs fixed capacity
- ✓ Special drawer finish for small materials: jigs, molds, parts, etc.



TOP VIEW

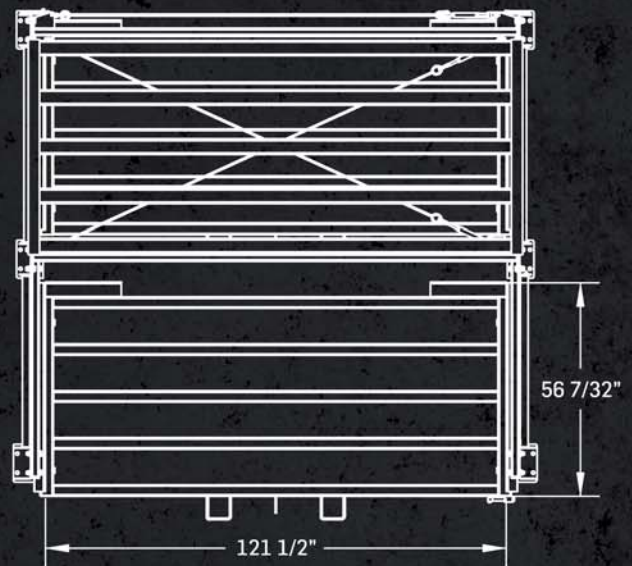

FRONT VIEW

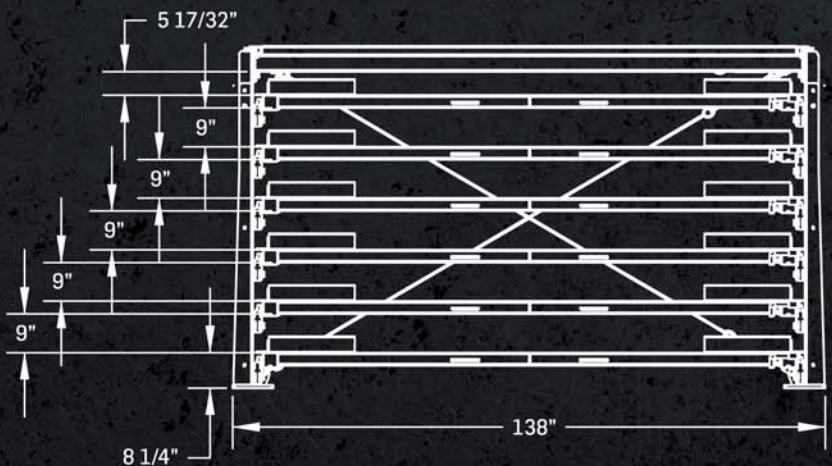

REQUEST QUOTATION FOR SHEET RACK

Date: _____	Customer name: _____
Distributor: _____	Customer city: _____
Contact: _____	Email: _____
Phone number: _____	Other information: _____

GENERAL INFORMATION

Opening type: Front Only Front and back

Drawer dimension: 4'x4' 4'x8' 4'x10' 5'x10' 5'x12' 6'x12'

Shelf height: 80" Other

Capacity per drawer: _____ (Standard 5,000 lbs)

Number of levels: _____ (8 max for the 80" high unit)

Minimum space between levels: _____

Doors: Yes No

X-brace: **Gussets:** *(If loading from the back check Gussets)*

On top storage: Yes No

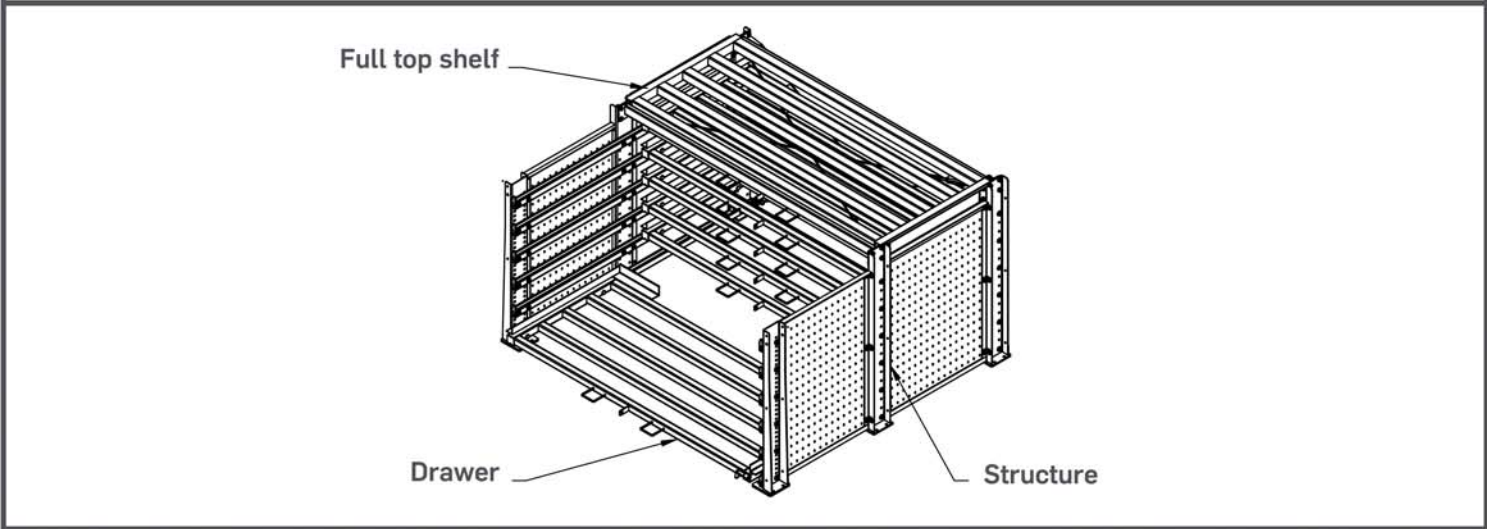



**ROLL OUT
RACKS**

MANUFACTURED BY  **INDUSTRIUM**

3637, Isabelle Street, Brossard (QC) J4Y 2R2

T 1-800-971-1549

info@rolloutracks.ca

ROLLOUTRACKS.COM